

(12) UK Patent Application (19) GB (11) 2 070 922 A

(21) Application No 8103704
(22) Date of filing
6 Feb 1981
(30) Priority data
(31) 8004673
(32) 12 Feb 1980
(33) United Kingdom (GB)
(43) Application published
16 Sep 1981
(51) INT CL³ A46B 11/02
(52) Domestic classification
A4K 158 161 162 165
167 168 175 185 BA
(56) Documents cited
GB 1124223
GB 1032673
GB 932105
GB 853780
GB 399434
GB 375747
GB 375232
GB 365102
GB 228286
GB 202828
US 3879139A
US 3738761A

US 3612706A
US 3501243A
(58) Field of search
A4K
A5R
(71) Applicant
Lingner & Fischer GmbH
D-7580 Buhl (Baden),
Postfach 1440
West Germany
(72) Inventors
Herbert Brieda
Rolf Kawa
(74) Agents
Mr B J Russell
Beecham
Pharmaceuticals
Great Burgh
Yew Tree Bottom Road
Epsom
Surrey
KT18 5XQ
England

(54) Oral hygiene apparatus

(57) Oral hygiene apparatus in the form of a toothbrush comprising a treatment head 30 movably mounted on a handle 10, the head 30 being provided with bristles 32 and a plurality of discharge ducts 33 for supplying treatment material to the bristles 32, the head being arranged to move between a first position in which the ducts 33 are closed to prevent the supply of treatment material and a second position in which the ducts 33 are open to permit supply of the material to the elements 32. The cross-section of passage 11 may increase towards the outer extremity of head 30.

The apparatus may be used in combination with an interchangeable reservoir of treatment material e.g. dentrifice.

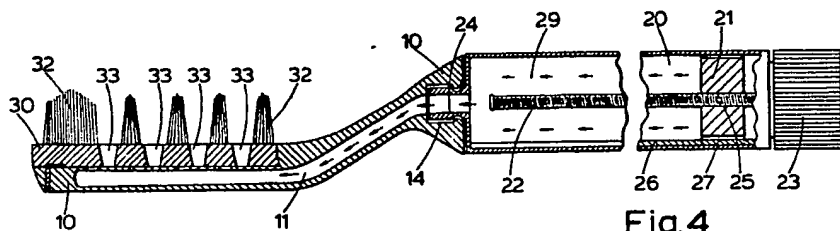

Fig.4

UDZUUVU776V

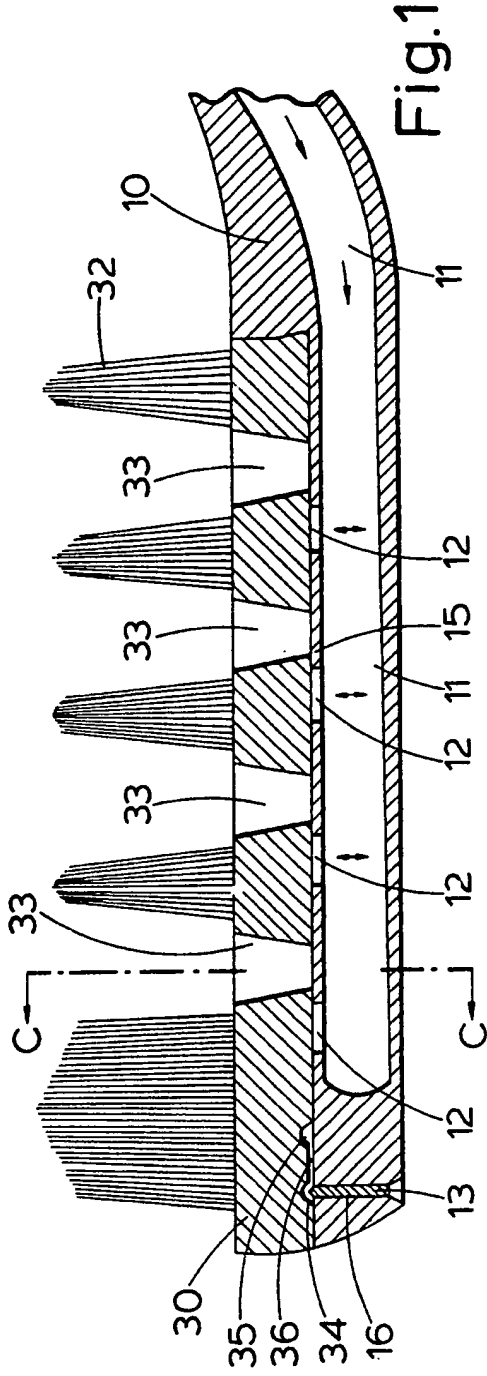

Fig. 1

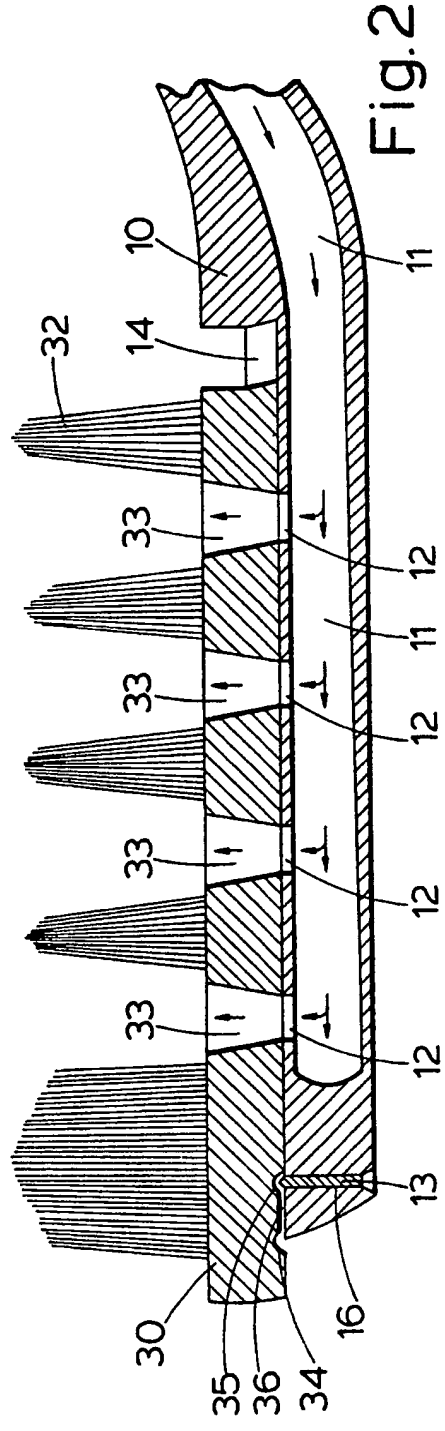

Fig. 2

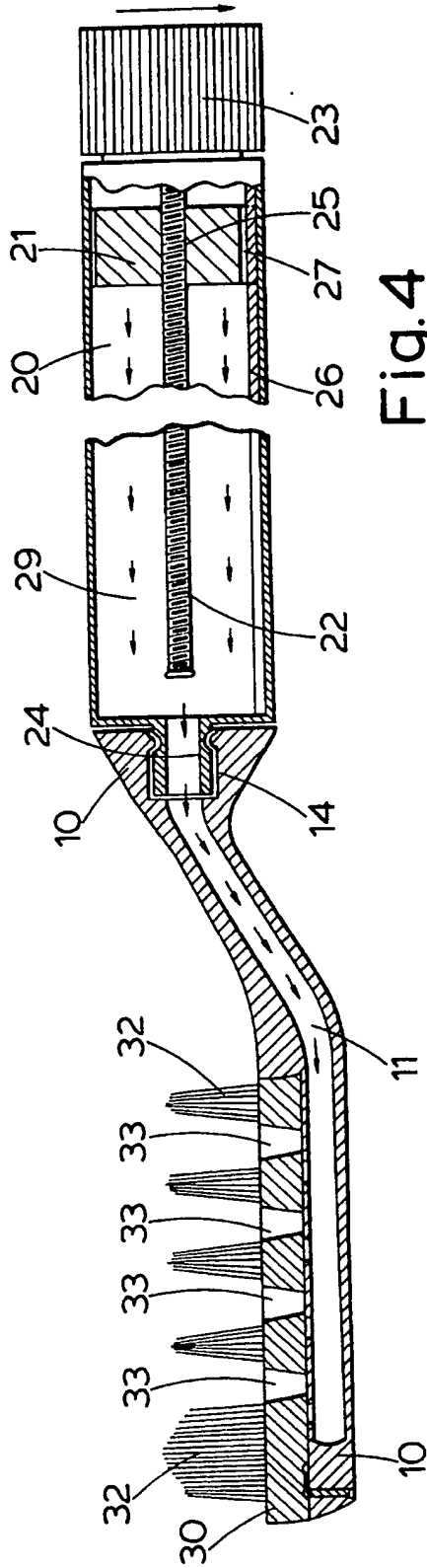

Fig. 4

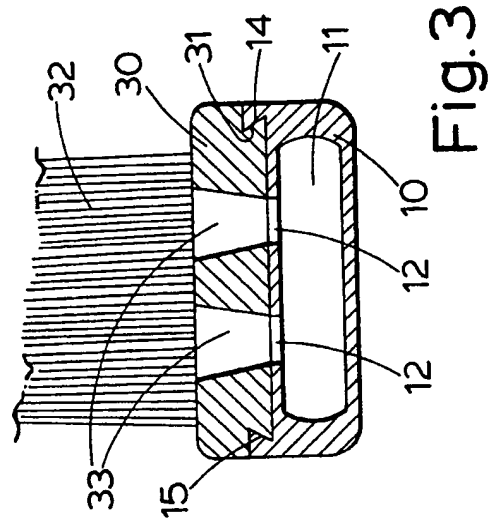

Fig. 3

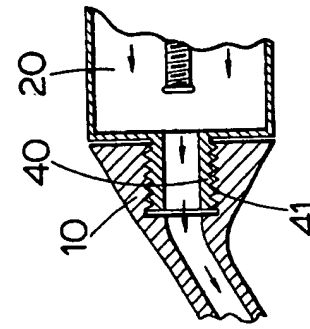

Fig. 5a

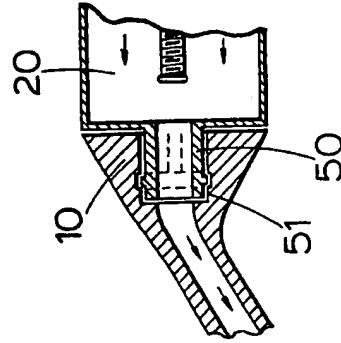

Fig. 5b

SPECIFICATION

Oral hygiene apparatus

- 5 The present invention relates to oral hygiene apparatus and particularly, though not exclusively to a toothbrush designed to be connected to a reservoir of dentrifice, for direct application of the dentrifice to the teeth.
- 10 Previously known toothbrushes of the type in which a dentrifice can be extruded into the bristles through a bristle head possess a number of disadvantages; for example, the extrusion opening for the dentrifice in the bristle head is apt to clog, distribution of dentrifice throughout the bristle head is not homogeneous, the dentrifice reservoir is difficult to fill, and it is necessary to discard the complete brush when the bristles become worn.
- 15 It has now been found that an apparatus of the type specified embodying an improved sealing and supply system helps to overcome the said disadvantages and may be manufactured from plastics material at low cost.
- 20 Accordingly, the present invention provides an oral hygiene apparatus comprising a treatment head movably mounted on a handle, the head being formed or provided with at least one tooth or gum treatment element and a plurality of discharge ducts for supplying treatment material to the element, the head being arranged to move between a first position in which the ducts are closed to prevent the supply of treatment material and a second position in which the ducts are open to permit supply of the material to the element.
- 25 Preferably the head is detachably mounted on the handle.
- 30 Suitably the head is slidable on the handle between the first and second positions.
- 35 In a particularly preferred embodiment of this invention the handle is formed with an internal passage for connecting the discharge ducts to a supply of treatment material.
- 40 A uniform supply of treatment material to the treatment element may be obtained from the discharge ducts connected to an internal passage in which the cross section of the internal passage increases towards the outer extremity of the head.
- 45 Removal of residual treatment material from the head and in particular from the discharge ducts is facilitated by constructing each discharge duct so that its cross section increases in the direction of discharge of treatment material through the ducts.
- 50 The optimum method of application of treatment material to the teeth or gums depends upon the viscosity of the treatment material and the physical condition of the mouth cavity and therefore included within the scope of this invention is an apparatus in which the or each treatment element is in the form of bristles, felt rods, cushions or sponges.
- 55 The apparatus may be used to apply liq-

uids, lotions and creams to the oral cavity, including medicaments for therapeutic treatment of the oral cavity and teeth.

- 60 Suitably the apparatus is used in combination with a reservoir of treatment material; the treatment material being preferably a dentrifice.

65 A particular embodiment of the invention in the form of a toothbrush will now be described by way of example with reference to the accompanying drawings, in which:-

70 *Figure 1* is a vertical section through the head and part of the handle of a toothbrush with the discharge ducts closed.

- 75 *Figure 2* is a vertical section through the head and part of the handle of the toothbrush with the discharge ducts open.

80 *Figure 3* is a sectional view along the line C-C of Fig. 1.

- 85 *Figure 4* is a vertical section along the longitudinal axis of the toothbrush in combination with a reservoir for dentrifice.

90 *Figure 5a and 5b* are vertical sections of alternative connections between the toothbrush and an interchangeable reservoir.

Referring to Fig. 1 of the drawings oral hygiene apparatus in the form of a toothbrush comprises a treatment head slidably mounted on a handle 10.

- 95 The treatment head 30 is formed with a number of discharge ducts 33 and carries bristles 32 for application of dentrifice to the teeth and gums. The handle 10 is formed with an internal passage 11 increasing in cross section towards the end remote from the supply of dentrifice giving a pressure gradient in the dentrifice to ensure uniform supply of dentrifice to each discharge duct 33. The upper surface 15 of the handle 10 contains a number of holes 12; the holes 12 are shown out of registry with the ducts 33 and sealed off by the treatment head 30. The discharge ducts 33 have an increasing cross sectional area in the direction of discharge of dentrifice through the duct to enable easier removal of residual dentrifice from the ducts 33 after use.

- 100 The head 30 is retained in position with the discharge ducts 33 closed, by means of a locating pin 13, housed in a bore 16 in the handle 10, which engages a recess 34 in the underside of the head 30.

105 Referring to Fig. 2 of the drawings the toothbrush is shown with the discharge ducts 33 open to receive dentrifice.

- 110 The treatment head 30 has been moved from the position shown in Fig. 1 in a direction parallel to the handle 10 until the locating pin 13 engages with a second locating recess 35 in the underside of the head 30. A slot 36 between the recess 34 and the recess 35 offers sufficient resistance to movement to prevent random longitudinal movement of the treatment head 30. The locating pin 13 will snap fit into each recess 34 and 35 thereby

providing a positive location for the head 30 on the handle 10. Withdrawal of the locating pin 13 from the bore 16 allows the complete removal of the treatment head 30 for replacement or sterilisation.

In the open position the holes 12 in the handle 10 are in registry with the discharge ducts 33 enabling dentrifice to be supplied through the ducts 33 to the bristles 32.

Referring to Fig. 3 of the drawings, a dovetail joint 15 is formed between the head 30 and handle 10 preventing lateral movement of the head relative to the handle.

The dovetail joint 15 is formed by an angular projection 14 on the handle 10 snugly mating with an angular recess in the head 30.

Referring to Fig. 4 of the drawings, the toothbrush is shown in combination with a reservoir of dentrifice.

A cylindrical reservoir body 20 contains a snugly fitting piston 21 with central threaded bore 25, and a supply of dentrifice 29. A screw head 23 carried a threaded rod 22 which co-operates with the bore 25 in the piston 21. The periphery of the piston 21 is formed with an axial slot 27 which engages an axial ridge 26 formed on the internal surface of the reservoir body 20, thereby preventing rotation of the piston 21. Rotation of the screw head 23 rotates the threaded rod 22 causing the piston 21 to move along the rod 22, thus, propelling dentrifice 29 through the internal passage 11 and subsequently through the ducts 33 to the bristles 32.

The reservoir body carried a male connector 24 which is a snap-fit with a corresponding female connector 14 in the handle 10 enabling replacement of an empty reservoir with one filled with fresh dentrifice or alternative treatment material.

Fig. 5a shows an alternative method of joining the reservoir body 20 to the handle 10 using a screw connection, while Fig. 5b shows a method of connection using a bayonet joint.

CLAIMS

1. Oral hygiene apparatus comprising a treatment head movably mounted on a handle, the head being formed or provided with at least one tooth or gum treatment element and a plurality of discharge ducts for supplying treatment material to the element, the head being arranged to move between a first position in which the ducts are closed to prevent the supply of treatment material and a second position in which the ducts are open to permit supply of the material to the element.

2. Apparatus according to claim 1 in which the head is detachably mounted on the handle.

3. Apparatus according to claim 1 or claim 2, in which the head is slidable on the handle between the first and second positions.

4. Apparatus according to any one of claims 1 to 3, in which the handle is formed with an integral passage for connecting the discharge ducts to a supply of treatment material.

5. Apparatus according to claim 4 in which the cross section of the internal passage increases towards the outer extremity of the head.

6. Apparatus according to any one of claims 1 to 5, in which the cross section of each discharge duct increases in the direction of discharge of treatment material through the ducts.

7. Apparatus according to any one of claims 1 to 6, in which the or each treatment element is in the form of bristles, felt rods, cushions or sponges.

8. Apparatus according to any one of claims 1 to 7, in combination with a reservoir of treatment material.

9. Apparatus according to any one of claims 1 to 8 in which the treatment material is a dentrifice.

10. Apparatus substantially as described hereinbefore, with reference to Figs. 1, 2 and 3 of the accompanying drawings.

11. Apparatus substantially as described hereinbefore, with reference to Fig. 4 of the accompanying drawings, or when modified as shown in Fig. 5a or 5b of the accompanying drawings.